

**TAG RACING INTERNATIONAL™**

*Manufacturer Address*  
**PRD TAIWAN**  
6F, No16 Nanking East  
Road, Section 5, Taipei TW

Engine #
----------

Manufacturer :	<b>PRO RACING DESIGN</b>
Make:	PRD
Model :	FIREBALL RK125WC.07
Inlet type:	REED
Number of pages	

**PICTURE OF ENGINE**

*(insert picture of front/left here)*



*(insert picture of back/right here)*



**Signature and Stamp**

--	--

Importer	
----------	--



**TECHNICAL INFORMATION**

A	CHARACTERISTICS	
	Measurement	Tolerances
Volume of cylinder	<b>122.25 cc</b>	<b>125 cc</b>
Original bore	<b>53.60 mm</b>	
Theoretical maximum bore	<b>54.25 mm</b>	
Stroke	<b>54 mm</b>	<b>±0.05</b>
Cooling system	<b>WATER COOLED</b>	
Number of carburation systems	<b>Tillotson (HL-360A) ONE ONLY</b>	
Number of transfer ports / ducts, cylinder / sump	<b>3</b>	
Number of exhaust ports / ducts	<b>3</b>	
Shape of the combustion chamber	<b>SPHERICAL WITH SQUISH</b>	
Length between axes of the connecting rod	<b>100 mm</b>	<b>±0.10 mm</b>
Minimum weight of connecting rod	<b>120 g</b>	<b>±5 g</b>
Volume of combustion chamber	<b>10cc min</b>	
Type of bearings and size	<i>Example 6205 type</i> Big End of Con. Rod Bearing = <b>18 X 24 X 14.8</b> Little End of Con. Rod Bearing = <b>14 X 18 X 17.2</b> Crankshaft Bearing = <b>25 X 52 X 15</b>	

B	OPENING ANGLES	
Exhaust	<b>174 MAX</b>	
Of exhaust ports / ducts	<b>174 MAX</b>	

C	LIST OF ACCESSORIES INCLUDED	
<i>(List accessories as shown below)</i>	<i>Centrifugal clutch</i>	
<i>Carburetor with butterfly Ø27</i>		
<i>Electric starter</i>		
<i>Exhaust with flex</i>		

D	MATERIAL	
Cylinder	<b>Alloy</b>	
Connecting rod	<b>STEEL</b>	
Crankshaft	<b>STEEL</b>	
Head	<b>ALLOY</b>	
Liner	<b>CAST IRON</b>	
Crankcase	<b>ALLOY</b>	
Piston	<b>ALLOY</b>	
Piston Ring	<b>CAST IRON CHROME PLATED</b>	



**DRAWING OF THE CYLINDER DEVELOPMENT**

*(Insert drawing here)*

Chord reading	
B	65.3 + - 0.2
C1=C2	26 + - 0.2
C3	29.4 + - 0.2
Angular reading by inserting a 0.2mm gauge	
E	33.8 min
F	44 + - 0.2
G	43.5 + - 0.2

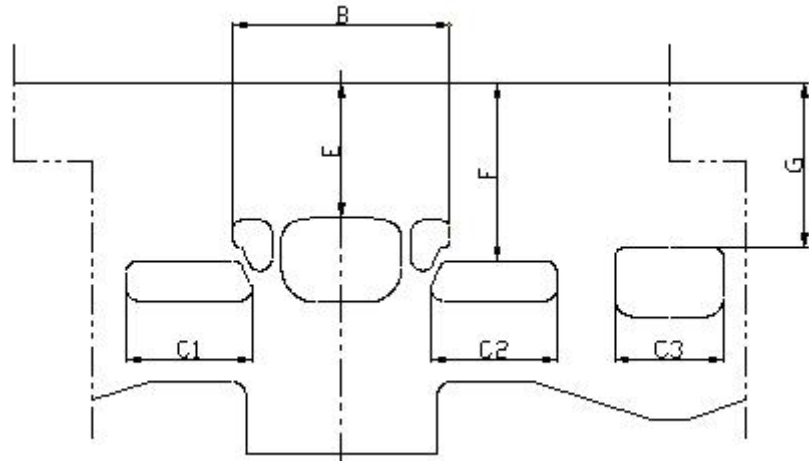

**DRAWING OF THE CYLINDER BASE**

*(Insert drawing here)*

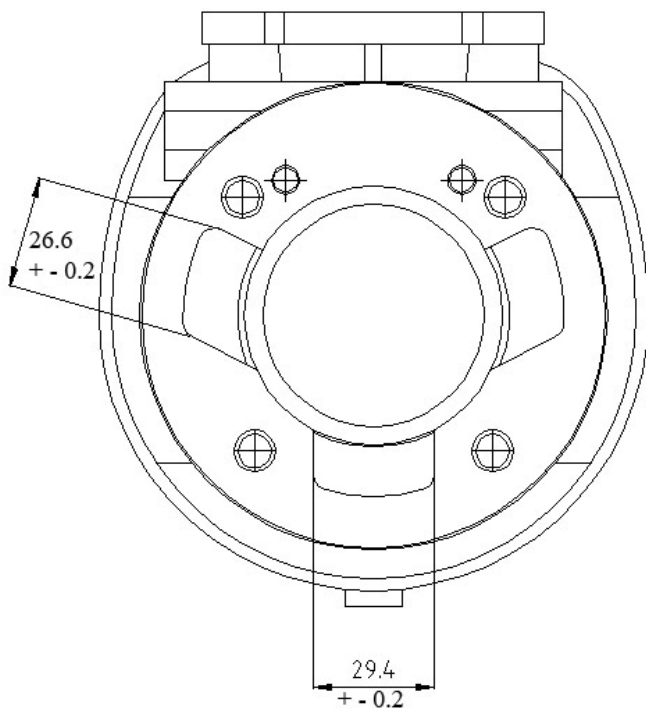

**CYLINDER SECTION VIEW**

*(Insert drawing here)*

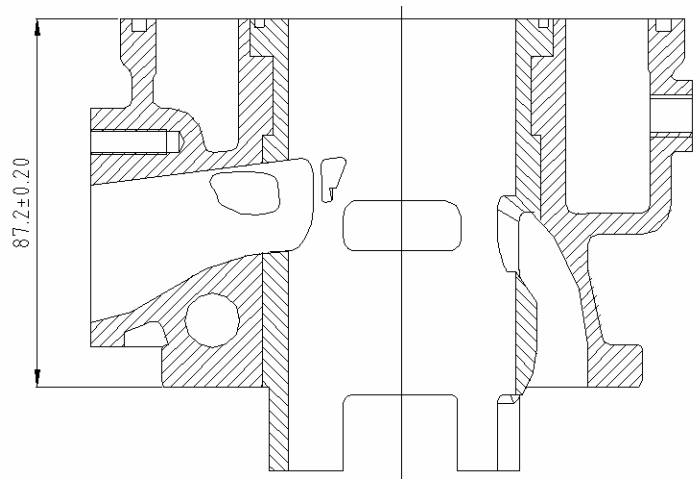



**DRAWING OF THE CYLINDER HEAD AND THE COMBUSTION CHAMBER**

*(Insert drawing here)*

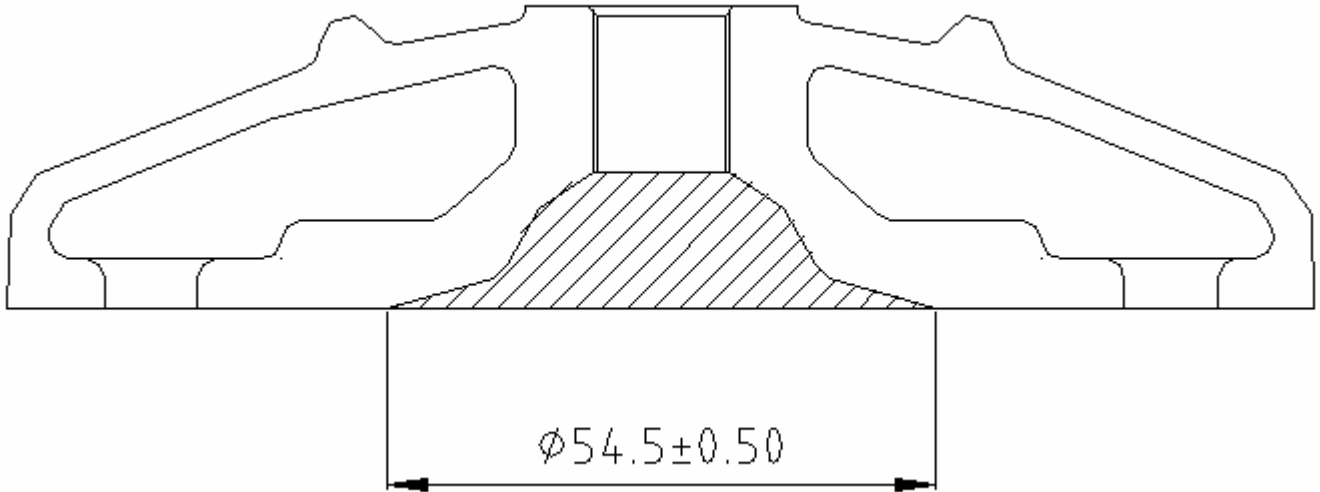

Combustion chamber volume =      c.c. minimum

**DRAWING OF THE CRANKSHAFT**

*(Insert drawing here)*

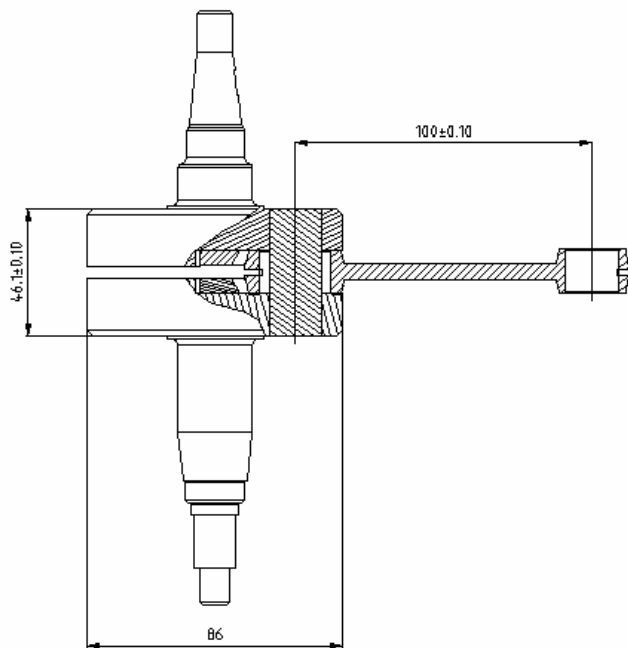



Complete weight = **1900 GRMS**  
Tolerance = **± 15 GRMS**

**DRAWING OF THE INSIDE OF SUMP**

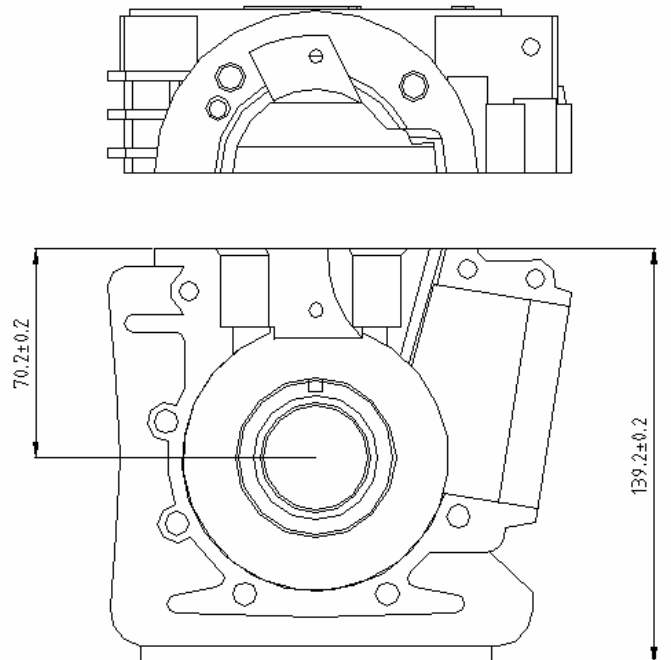

*(Insert drawing here)*





<b>IGNITION</b>	
Manufacturer	<b>OPPAMA</b>
Model Number	<b>PRD/OPPAMA/2004 -</b>
Rotation	<b>A/CLOCKWISE</b>
Description	<b>CDI</b>
<b>PHOTO OF IGNITION</b>	<b>PHOTO OF COIL</b>
<i>(insert photo of inside here)</i>	<i>(Insert photo here)</i>
	
<b>OPPAMA ROTOR</b>	<b>OPPAMA COIL</b>



<b>IGNITION</b>	
Manufacturer	<b>PVL</b>
Model Number	<b>PVL IGNITION (KEY IS NOT REQUIRED)</b>
Rotation	<b>A/CLOCKWISE</b>
Description	
<b>PHOTO OF IGNITION</b> <i>(insert photo of inside here)</i>	<b>PHOTO OF COIL</b> <i>(Insert photo here)</i>
 <p>PVL STATOR &amp; ROTOR</p>	 <p>PVL COIL</p>

**INTAKE**

Manufacturer

Model Number

Rotation

Description

**PHOTO OF REED ASSEMBLY**

*(insert photo of inside here)*



**PHOTO OF REED PETAL**

*(Insert photo here)*



*(insert photo of outside here)*





**CARBURETOR DIMENSION**

*(Insert drawing here)*

Item	Measure	Tolerance
A	33.75mm	±0.20mm
B	-----	-----
C	24mm	±0.10mm
D	24mm	±0.10mm
E	27mm	±0.10mm
F	66.25mm	±0.10mm

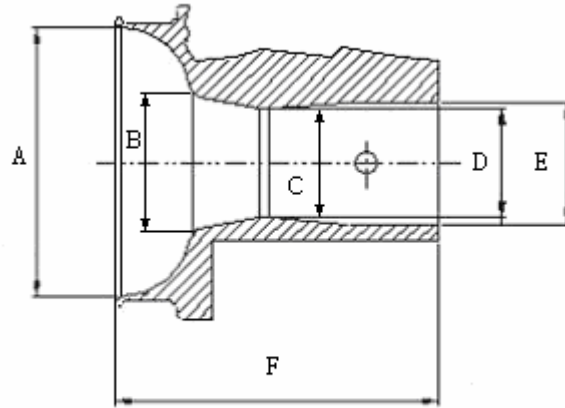

**PISTON**

*(Insert drawing here)*

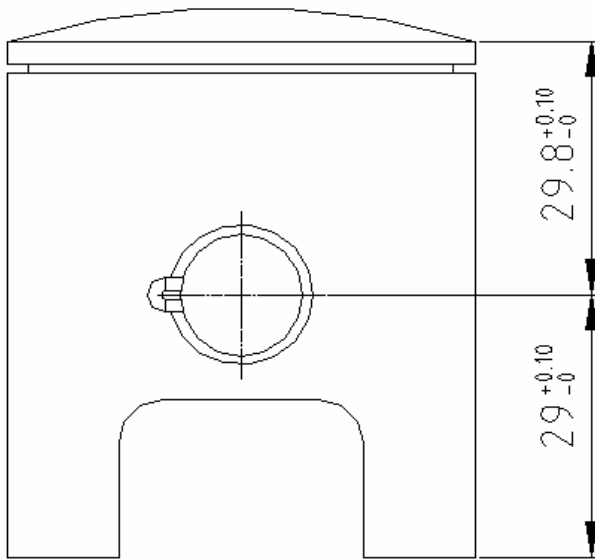

Weight= 135

Tolerance= ± 5

**CONNECTING ROD**

*(Insert drawing here)*

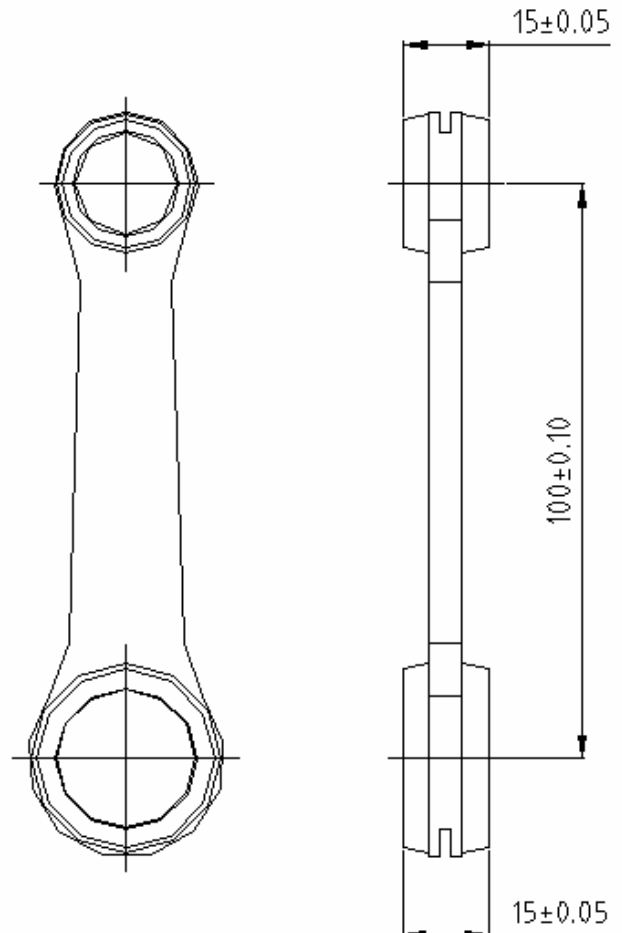

Weight= 120

Tolerance= ± 5



**DRAWING OF THE SILENCER AND IT'S COMPONENTS**

*(Insert drawing here)*

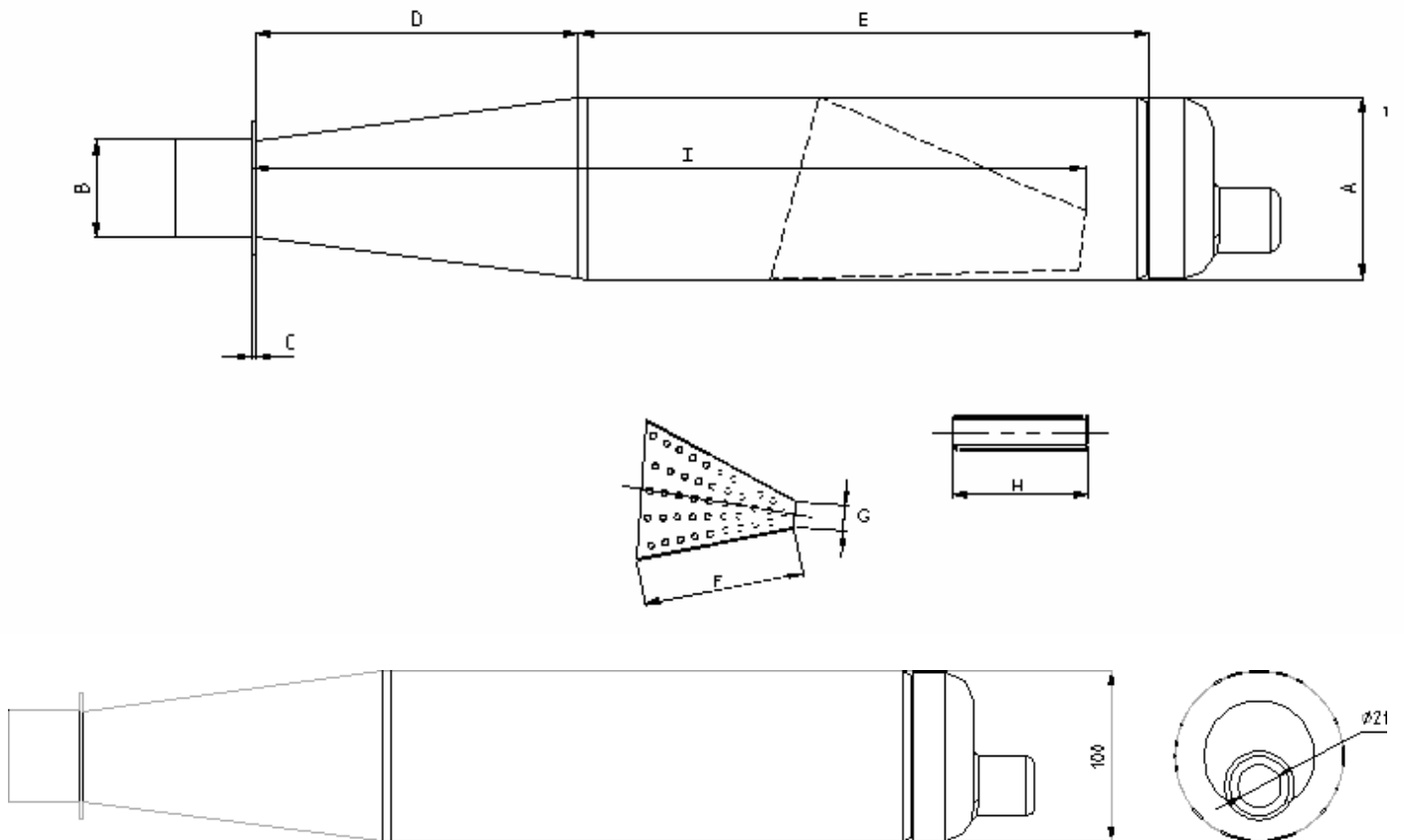

The end parts of the silencer must have two soldered pairs of lugs (one pair at the top and one pair at the bottom) to allow for fixing of seals by the Organizer so that the silencer may be opened during the competition

Measurements:

- A: 100mm
- B: 54mm
- C: 3mm
- D: 170mm
- E: 315mm
- F: 170mm
- G: 21mm
- H: 135mm
- I: 455m

**±1.00 mm ON ALL MEASUREMENTS**



**DRAWING OF THE CLUTCH**

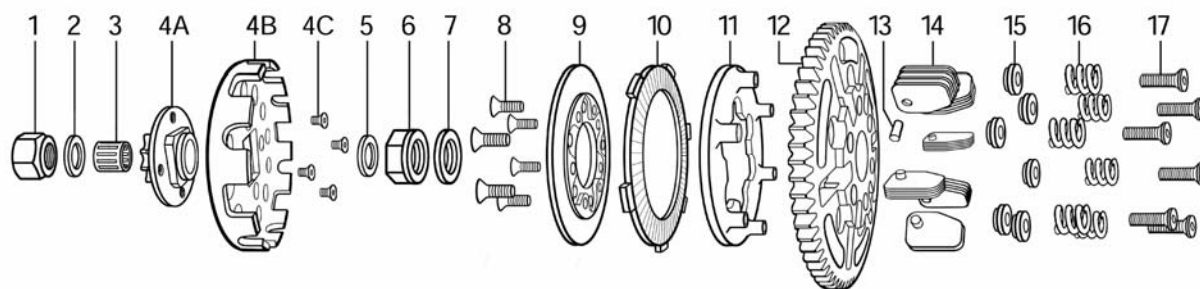

*HORSTMAN CLUTCH*

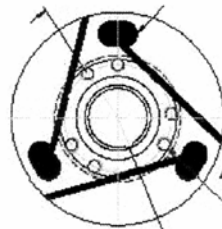
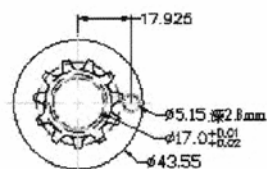
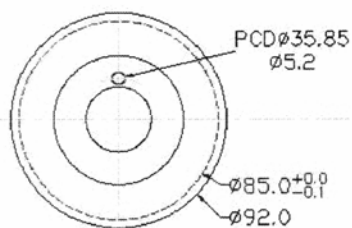

*PRD ONE PIECE CLUTCH*